



# MODEL 200 Bedknife Grinder

(Manual Includes Optional 20520 Pneumatic Traverse Kit)

## OWNERS MANUAL



### WARNING

You must thoroughly read and understand this manual before operating the equipment, paying particular attention to the Warning & Safety instructions.

# SAFETY INSTRUCTIONS



**Safety Awareness Symbols** are inserted in this manual to alert you to possible **Safety Hazards**. Whenever you see these symbols, follow their instructions.



The **Warning Symbol** identifies special instructions or procedures which, if not correctly followed, could result in personal injury, or loss of life.

The **Caution Symbol** identifies special instructions or procedures which, if not strictly observed, could result in damage to or destruction of equipment.

1. **KEEP GUARDS IN PLACE** and in working order.
2. **REMOVE ADJUSTING KEYS AND WRENCHES.**
3. **KEEP WORK AREA CLEAN.**
4. **DON'T USE IN DANGEROUS ENVIRONMENT.** Don't use power tools in damp/ wet locations, or expose them to rain. Keep work area well lit.
5. **KEEP ALL VISITORS AWAY.** All visitors should be kept at a safe distance from the work area.
6. **MAKE WORKSHOP CHILD-PROOF.** With padlocks or master switches.
7. **DON'T FORCE THE GRINDER.** It will do the job better and safer if used as specified in this manual.
8. **USE THE RIGHT TOOL.** Don't force the grinder or an attachment to do a job for which it was not designed.
9. **WEAR PROPER APPAREL.** Wear no loose clothing, gloves, neckties, or jewelry which may get caught in moving parts. Nonslip foot wear is recommended. Wear protective hair covering to contain long hair.
10. **ALWAYS USE SAFETY GLASSES.**
11. **SECURE WORK.** Mount the bed knife in place before grinding as prescribed in the operations manual.
12. **DO NOT OVERREACH.** Keep proper footing and balance at all times.
13. **MAINTAIN GRINDER WITH CARE.** Follow instructions in Service Section for lubrication and preventive maintenance.
14. **DISCONNECT POWER BEFORE SERVICING.**
15. **REDUCE RISK OF UNINTENTIONAL STARTING.** Make sure switch is in OFF position before plugging in the grinder.
16. **USE RECOMMENDED ACCESSORIES.** Consult the manual for recommended accessories. Using improper accessories may cause risk of personal injury.
17. **CHECK DAMAGED PARTS.** A guard or other part that is damaged or will not perform its intended function, should be properly repaired or replaced.
18. **NEVER LEAVE GRINDER RUNNING UNATTENDED. TURN POWER OFF.** Do not leave grinder until it comes to a complete stop.
19. **KNOW YOUR EQUIPMENT.** Read this manual carefully. Learn its application and limitations as well as specified potential hazards.
20. **KEEP ALL SAFETY DECALS CLEAN & LEGIBLE.** If safety decals become damaged or illegible for any reason, replace immediately. Refer to replacement parts illustrations in Service Section for the proper location and part numbers of safety decals.
21. **DO NOT OPERATE THE GRINDER WHEN UNDER** the influence of drugs, alcohol, or medication.

# SAFETY INSTRUCTIONS



## **IMPROPER USE OF GRINDING WHEEL MAY CAUSE BREAKAGE AND SERIOUS INJURY.**

Grinding is a safe operation if the few basic rules listed below are followed. These rules are based on material contained in the ANSI B7.1 Safety Code for "Use, Care and Protection of Abrasive Wheels". For your safety, we suggest you benefit from the experience of others and follow these rules.

### **DO**

1. **DO ALWAYS HANDLE AND STORE** wheels in a careful manner.
2. **DO VISUALLY INSPECT** all wheels before mounting for possible damage.
3. **DO CHECK MACHINE SPEED** against the established maximum safe operating speed marked on wheel.
4. **DO CHECK MOUNTING FLANGES** for equal and correct diameter.
5. **DO USE MOUNTING BLOTTERS** when supplied with wheels.
6. **DO BE SURE WORK REST** is properly adjusted.
7. **DO ALWAYS USE A SAFETY GUARD COVERING** at least one-half of the grinding wheel.
8. **DO ALLOW NEWLY MOUNTED WHEELS** to run at operating speed, with guard in place, for at least one minute before grinding.
9. **DO ALWAYS WEAR SAFETY GLASSES** or some type of eye protection when grinding.

### **DON'T**

1. **DON'T** use a cracked wheel or one that **HAS BEEN DROPPED** or has become damaged.
2. **DON'T FORCE** a wheel onto the machine **OR ALTER** the size of the mounting hole--if wheel won't fit the machine, get one that will.
3. **DON'T EVER EXCEED MAXIMUM OPERATING SPEED** established for the wheel.
4. **DON'T** use mounting flanges on which the bearing surfaces **ARE NOT CLEAN, FLAT AND FREE OF BURRS.**
5. **DON'T TIGHTEN** the mounting nut **EXCESSIVELY.**
6. **DON'T GRIND ON THE SIDE OF THE WHEEL** (See Safety Code B7.2 for exception).
7. **DON'T** start the machine until the **WHEEL GUARD IS IN PLACE.**
8. **DON'T JAM** work into the wheel.
9. **DON'T STAND DIRECTLY IN FRONT** of a grinding wheel whenever a grinder is started.
10. **DON'T FORCE GRINDING** so that motor slows noticeably or work gets hot.



**AVOID INHALATION OF DUST** generated by grinding and cutting operations. Exposure to dust may cause respiratory ailments. Use approved NIOSH or MSHA respirators, safety glasses or face shields, and protective clothing. Provide adequate ventilation to eliminate dust, or to maintain dust level below the Threshold Limit Value for nuisance dust as classified by OSHA.

# SAFETY INSTRUCTIONS

This machine is intended for grinding bedknives from reel mowing units **ONLY**. Any other use than the one intended may cause personal injury and void the warranty.



To assure the quality and safety of your machine and to maintain the warranty, you **MUST** use original equipment manufacturers replacement parts and have any repair work done by a qualified professional.

All operators of this equipment must be thoroughly trained before operating the equipment. Machine is for **INDOOR USE ONLY**. Do not use a power washer to clean the machine.



Symbols for *Read operators manual, wear safety glasses and disconnect power before servicing.*



Symbol to *Keep visitors at a safe distance away from the grinder.*



Symbol for *Sharp object which will cause serious injury.*



Symbol identifying a panel, cover, or area as having live electrical components within.

## DAILY MAINTENANCE BY OPERATOR

On a daily basis, clean the grinder by wiping it off.

On a daily basis, inspect the grinder for loose fasteners or components.

Contact your company's Maintenance Department if damaged or defective parts are found.

# ASSEMBLY

**We appreciate...** your involvement in the purchase and use of the Neary Model 200 Bedknife Grinder. Neary Technologies has been a manufacturer of sharpening equipment for lawn mowers since 1978. All of our products relate to sharpening turf related equipment. We are dedicated to manufacturing this equipment in a way that makes your job easier. Your questions and suggestions are welcome.

**The Model 200 Bedknife Sharpening System** is offered in two versions:

<u>Feature</u>	<u>200</u>	<u>200</u> with optional pneumatic Traverse Kit
Centers for Mounting Bedknife	Yes	Yes
Infeed, Manual Control	Yes	Yes
Travel, Manual	Yes	
Travel, Automatic		Yes

**Power Requirements:** 115 Volts, 50/60 Hz, 15 Amps

**Dimensions:** 84" long x 30" wide x 48" high, 250 pounds

**Shipping Dimensions:** 60" long x 30" wide x 76" high, 280 pounds, 79.2 cubic feet

Please record this information for ready reference when calling for replacement parts:

Model \_\_\_\_\_ Serial # \_\_\_\_\_

Purchase Date \_\_\_\_\_

Purchased From \_\_\_\_\_

Address \_\_\_\_\_

City, State, Zip Code \_\_\_\_\_

Phone \_\_\_\_\_ Fax \_\_\_\_\_

# ASSEMBLY

## UPON ARRIVAL . . . .

### Packing List

- 1 Model 200 Grinder
- 2 20028 Rails
- 1 Carriage Assembly
- 1 Parts Box (for contents of parts box see first page of parts list)

### Site Requirements

- Indoors
- Dry
- Reasonably level - cement floor
- Good Lighting
- 115 Volts, 50/60 Hertz, 15 Amp outlet
- Adequate access to the front of the machine for the operator.
- Optional Pneumatic Traverse Kit 20520 requires compressed air supply line for the pneumatic system that powers the automatic travel.
- **Move the machine to the site, then proceed with assembly.**

## ASSEMBLY

The Model 200 is shipped on a pallet, assembled, except for the rails, carriage, and a few small attachments.

1. Remove the crate from the machine using a hammer.
2. Carefully use the utility knife to remove the protective wrapping.
3. Remove from pallet and set on floor.



**The Main Base Assembly weighs 250 lbs (122 kg).  
To lift, use power equipment or get adequate help.**

4. Remove the rails from the paper tubes and install in the mounting brackets. Rail extension from the brackets to the end of the rails is 24 inches to the left and 13 inches to the right.
5. Install the ring stops, one on each end of the rails to prevent the carriage from rolling off the ends of the rails.
6. Remove the carriage from the base and set on top of the rails.
7. Install the center bedknife support from the parts box.
8. Install the bedknife “hold down” from the parts box.

# ASSEMBLY

## Electrical Requirements:

- The unit is designed for 115 Volts, 50/60 Hertz, 15 Amps
- The unit requires a grounded 115 Volt 15 Amp circuit for operation.



**DO NOT** use extension cords. Voltage drop due to long cords or small gauge wire may cause this machine to malfunction.

## IMPORTANT GROUNDING INSTRUCTIONS

In case of a malfunction or breakdown, grounding reduces the risk of electrical shock by providing a path of least resistance for electrical current.

This grinder has an electrical cord with an equipment grounding conductor and a grounding plug. The plug must be plugged into a matching outlet that is properly installed and grounded according to all local or other appropriate electrical codes and ordinances.

Before plugging in the Grinder, make sure it will be connected to a supply circuit protected by a properly-sized circuit breaker or fuse.

Never modify the plug provided with the machine--if it won't fit the outlet, have a proper outlet and circuit installed by a qualified electrician.



**ALWAYS PROVIDE A PROPER ELECTRICAL GROUND FOR YOUR MACHINE. AN IMPROPER CONNECTION CAN CAUSE A DANGEROUS ELECTRICAL SHOCK. IF YOU ARE UNSURE OF THE PROPER ELECTRICAL GROUNDING PROCEDURE, CONTACT A QUALIFIED ELECTRICIAN.**

## Inspect Grinding Wheel:

The bedknife grinder has been supplied with a medium grit wheel Part #3700411. With proper use and care, this wheel will provide maximum grinding capability, accuracy, and safety. Prior to starting the machine, visually inspect the wheel for possible damage in shipment.



**If the grinding wheel appears to be damaged, DO NOT start the grinder.**

The Model 200 is now fully assembled and ready for the review of the operating instructions.



**Always wear proper safety eyewear, and respirator equipment when operating the Model 200.**



**Before operating this grinder, read the Operating Instructions.**

# WIRING INFORMATION

To convert this grinder to operate 50/60 Hz phase current, cut the cord and replace it with the plug for your locality. For plug breaker sizing, see motor nameplate. Use only a qualified electrician.

**NOTE:** This motor will operate on 60 Hz or 50 Hz power.

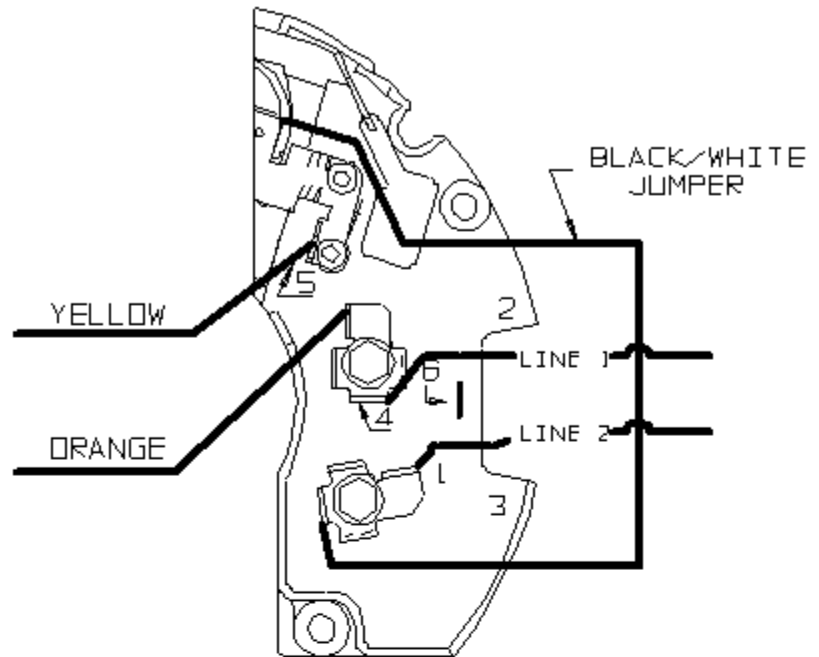

## WIRING FOR 115 VAC

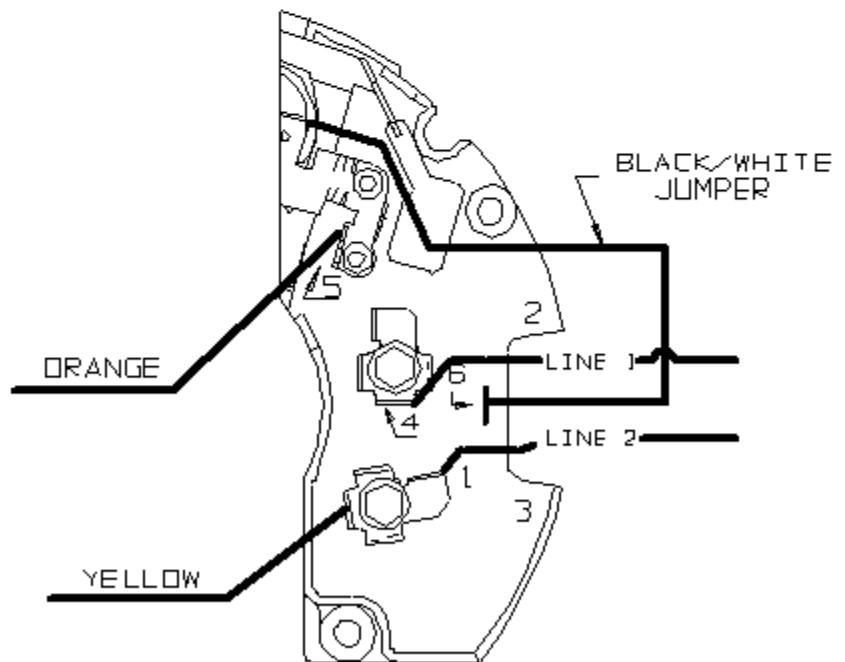

## WIRING FOR 220 VAC

# OPERATION

## OPERATION

### Terms:

- Bedknife, the stationary blade in a reel mower.
- Bedknife Support or Bedbar, the bedknife is mounted to this frame member with screws or rivets.
- Top Face, the horizontal, ground surface of the bedknife.
- Front Face, the vertical surface of the cutting edge of the bedknife.
- Top Relief Angle, the angle between the horizontal and the manufacturer's recommended sharpening angle.
- Front Relief Angle, the angle between the vertical and the manufacturer's recommended sharpening angle.

### The Controls for Model 200:

**On/Off Control:** This is the toggle switch on top side of the grind motor. See page 25.



**Always wear proper safety eyewear and respirator equipment when operating your grinder. Never turn on your grinder without first putting on this equipment.**



**The maximum recommended infeed is .006". This is approximately 1/12th of a turn of the knob, or a rotation of 30 degrees.**

Please note that turning the handle counterclockwise infeeds the grinding wheel, while turning the knob clockwise will move the grinding wheel away from the bedknife.

# OPERATION

## Before mounting the Bed Knife, check it for:

- Cleanliness
- Straightness
- Uneven wear
- Excess wear
- Damage to bed bar
- Loose screws or rivets

If the bedknife is excessively worn, replace the bedknife.

Replace any loose rivets, and tighten any loose screws.

## Mounting the Bedknife on the Bedknife Support:

Use this knob to adjust the bedknife **up or down** to make the bedknife travel true to the grinding wheel.

Use this knob to tighten the bedknife between the centers.

Loosen these knobs to **rotate** the bedknife for grinding the front face. Rotate, then secure by tightening knob.



Use these knobs to move the center supports back and forth on the trunnion bar.

Use this bracket to hold the front on the bedknife against the center bedknife support. Lay it in the gutter of the bedknife and tighten.

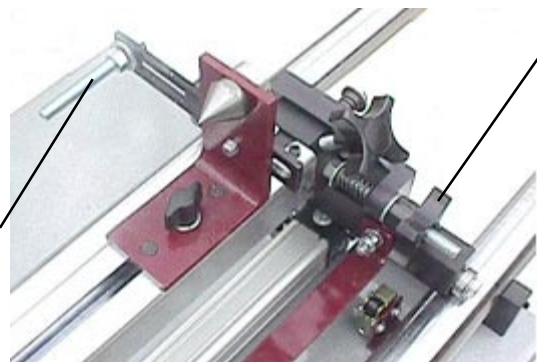

Use this knob to adjust the bedknife **in or out** to make it travel true to the grinding wheel.

## OPERATION

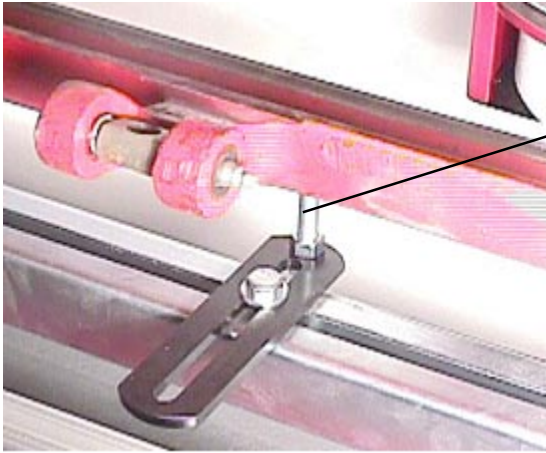

Adjust this stop to support the center of the bedknife.



Use the gauge to adjust the bedknife **in and out** by touching the front of the center on one end, then lift the rod, move the carriage and compare to the front of the cylinder on the other end. Repeat! This must be checked several times because when you move one end, the other end moves as well.

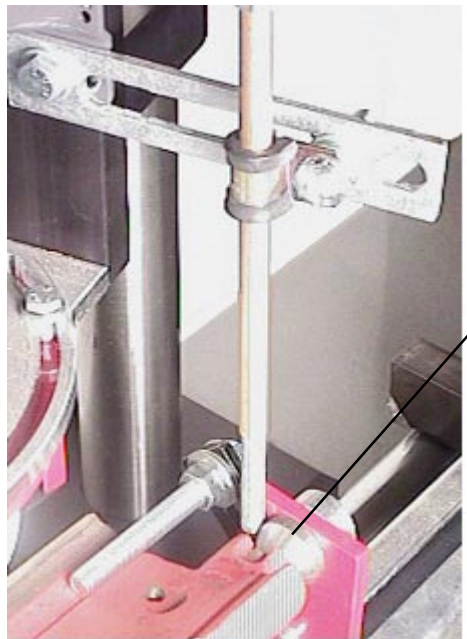

Use the gauge to adjust the bedknife **up and down** by touching the top of the center on one end, then lift the rod, move the carriage and compare to the top of the cylinder on the other end. Repeat! This must be checked several times because when you move one end, the other end moves as well.

# OPERATION

## Recommended Face & Top Angles

Manufacturers recommend that bedknife relief angles should always be maintained to original manufacturer's specifications. Neary Technologies has compiled these angles in a chart below. Angles vary depending on the manufacturer and model. We have included many of the popular models in the chart. If your model is not listed, consult the manual for the mower.

Some units do not have the front face ground. For example: Some Toro units (such as the 70" Pro) have a "stellite" hard coated surface. The Toro Turf Pro 84 has a factory ground front face. Consult the bedknife manufacturer when in doubt as to grinding the front face.

## Bedknife Grind Angles

# OPERATION

## Top Face Grinding

1. Mount the bedknife between the centers.
2. Rotate the bedknife and bedknife support forward until the angle finder (Part #3702707) reads the correct angle for grinding the top face. Firmly tighten the lever to assure the angle of the support and bedknife does not change during grinding.
3. The front of the wheel must extend into the gutter of the bedknife. If it does not extend into the gutter, the ground surface may not be flat after grinding. If necessary, rotate the grinding head to assure that the edge of the wheel extends into the gutter of the bedknife. Infeed the grinding wheel until it is a few thousandths of an inch away from the bedknife surface.
4. If the wheel does not clear the entire length of the bedknife, or if the bedknife is not aligned with the grinding wheel, it may be necessary to align the bedknife using the gauge and the adjustments for up & down and in & out.
5. When you have completed the set up, check to assure that all knobs and stops are secure, then with the grinder turned off, travel the carriage from end to end to assure that the grinding wheel will grind only the bedknife and clears all other parts of the machine and the bedknife.
6. If you have installed the optional Pneumatic Traverse Kit 20520, turn on the travel and adjust the rate of travel. If you have a 200 model, manually traverse and slowly infeed the grinding wheel, by turning the knob **counterclockwise**, until you are lightly grinding and complete several passes back and forth.
7. Continue grinding the bedknife in this manner until you are satisfied with the top face grind. Dress the wheel when necessary.
8. Dress the wheel before the final **spark out** grind.

By partially grinding both surfaces, the top face and the front face, you will sharpen a used bedknife with the least metal removal. Partially grinding both surfaces is the preferred method for life utilization of the bedknife.



**IMPORTANT!** When manually traveling the carriage on the Model 200, it is very important to use consistent speed and pressure. Do not lean on the machine or bump the rails.

## Front Face Grinding

**NOTE:** Some bedknives require front face grinding. Check with the bedknife manufacturer to determine if front face grinding is required.

1. Rotate the bedknife and bedknife support back to the desired angle.
2. Infeed the grinding wheel until it is a few thousandths of an inch away from the bedknife front surface.
3. If the grinding wheel does not clear the entire length of the bedknife, or if the bedknife is not aligned with the grinding wheel it may be necessary to align the bedknife.
4. Slowly infeed the grinding wheel knob until you are lightly grinding and have completed several passes down and back.
5. Continue infeeding until you have satisfactorily ground the front face.
6. Continue grinding the bedknife in this manner until you are satisfied with the front face grind. Dress the wheel when necessary.
7. Dress the wheel before the final **spark out** grind.

By partially grinding both surfaces, the top face and the front face, you will sharpen a used bedknife with the least metal removal. Partially grinding both surfaces is the preferred method for life utilization of the bedknife.



**IMPORTANT!** When manually traveling the carriage on the Model 200, it is very important to use consistent speed and pressure. Do not lean on the machine or bump the rails.

# MAINTENANCE

## Maintenance



**Before performing any maintenance procedure unplug the unit from its power source.**

Clean excess dirt and grit from machine daily.

Wipe grit and dirt from the carriage rails...daily!

Protect the rails with WD 40 to prevent rust.

Protect any bare metal surface from the atmosphere if the machine is not in use for extended periods of time.

### Dressing the Grinding Wheel:

The grinding wheel should be dressed anytime it becomes “loaded” or out of balance. The term “loaded” refers to the condition of the wheel when the surface of the wheel is clogged with material. Periodically dressing the grinding wheel will improve both the quality and the efficiency of the grind. The Model 200 comes with a dressing brick.

To dress the grinding wheel:

Move the carriage to one end.

Turn off the auto travel if you have the optional Pneumatic Traverse Kit 20520.

Carefully hold the dressing brick against the grinding wheel while the grinding wheel is rotating.



**Warning!** Keep hands and fingers away from the grinding wheel. For longer diamond dresser life, rotate the diamond dresser often.

**Changing the Grinding Wheel #3700411:** A wrench Neary #20045 is provided to remove the nut that holds the grinding wheel onto the adapter. The nut and adapter are **left hand thread**. To remove the wheel, hold the wheel and turn the nut **clockwise** (as viewed from the nut side of the wheel).

## MAINTENANCE

When installing a new grinding wheel, it is important to follow the instructions provided by the grinding wheel manufacturer. These instructions include the following important points:

Always unplug the grinder before installing a new wheel.

Always inspect the wheel for damage. Never use a wheel that appears to be cracked or chipped.

Always make sure there are blotters on each side of the wheel that are larger in diameter than the mounting flanges.

Always check to see that the wheel is rated for the same or greater RPM as the grinder.

Always check the flanges for damage. They must be flat and of the same diameter.

The wheel is mounted to an adapter that is in turn mounted to the motor shaft, check to assure that the adapter is tight to the shaft by tightening the set screws. Loose adapters may cause excessive vibration.

Inspect the threads on the wheel mounting adapter or hub. Note that the threads are be left hand thread.

When removing an old wheel and installing a new wheel, make sure the wheel mounting nut is tight, but not so tight as to crack the wheel by crushing it between the flanges.

With the machine unplugged, slowly rotate the wheel and check for running true. New wheels may be out of running true before dressing by 1/16". If running true appears to be a problem, loosen the mounting nut and rotate the wheel 90 degrees in relationship to the motor shaft. Check for running true again. Make sure all guards are in place. Wear Safety Glasses. Keep hands away from the wheel.

Start the grinder and check for excessive vibration. If necessary, turn the wheel 90 degrees up to two more times. When the wheel is mounted in the best position, it may also be "dressed" for running true across the grinding surface.

If reasonable balance is not attained after trying four positions on the grinding adapter 90 degrees apart, the wheel may not be properly balanced from the factory and should be returned for replacement.



**See WARNING on Page 3.**

# TROUBLESHOOTING

## Troubleshooting:

1. Ask Questions???
2. Double check the easy things first.
3. Establish a sequence.
4. Use common sense.
5. Use the manual.
6. SAFETY FIRST !!!

## Ask Questions ???

What does it do right?

What does it do wrong?

What won't it do?

Did it fail gradually?

Did it fail suddenly?

Did it ever work right?

What does the failure look like?

Did it smoke?

Was there a smell?

Were there any different sounds?

## NOTES:

# PARTS LIST: PARTS BOX

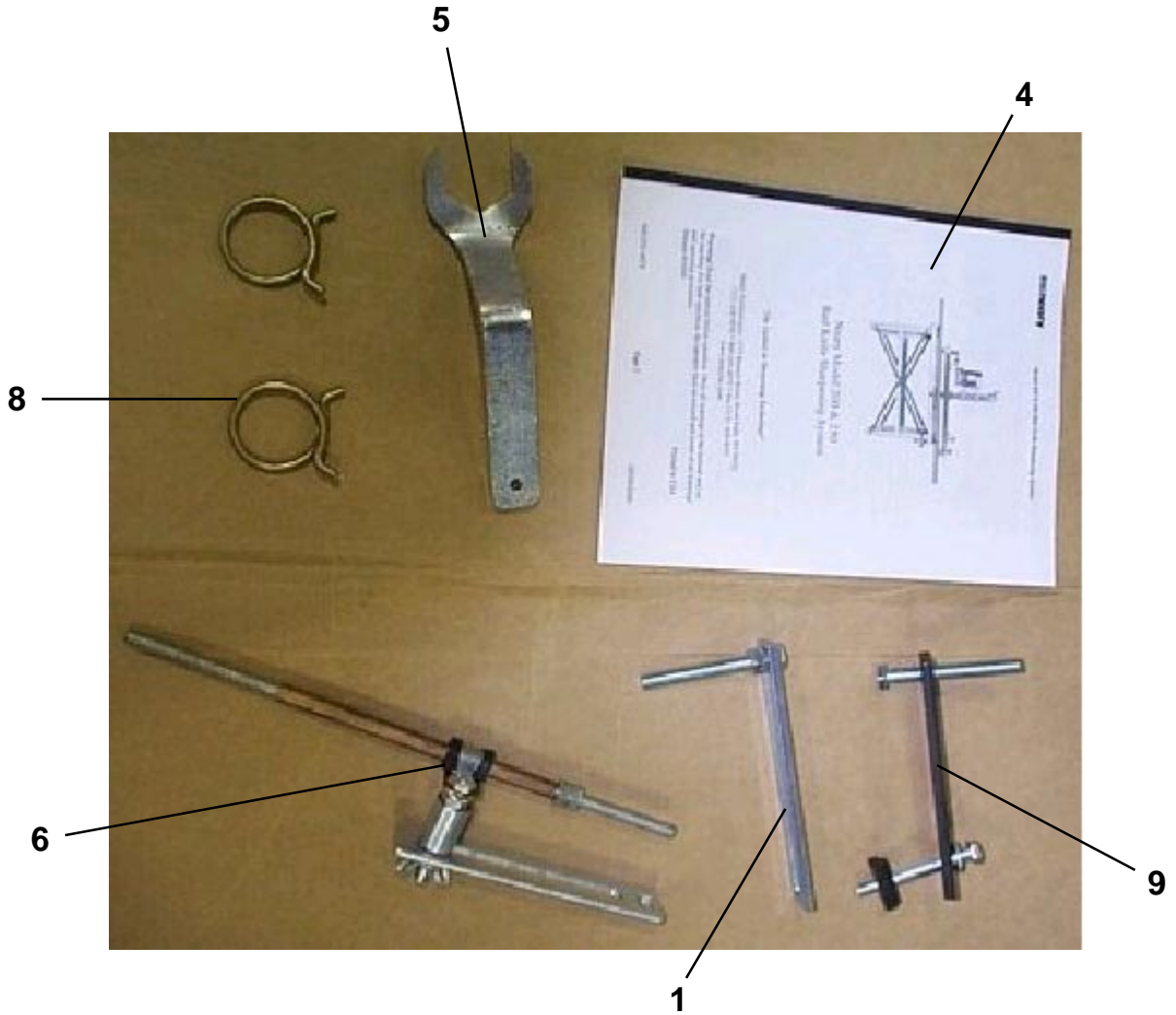

## Contents of Parts Box

Diagram No.	Part No.	Description
1 .....		Bedknife Support (See page 19)
4 .....	20000 .....	Manual / Parts List
5 .....	20045 .....	Wrench
6 .....	09339 .....	Gauge Assembly
8 .....	09326 .....	Hose Clamp Stops for Ends of Rails
9 .....		Bedknife Hold Down (See page 20)
10 .....	3702707 .....	Angle Finder--Magnetic (not shown)
11 .....	3702508 .....	Dressing Stick (not shown)

# PARTS LIST: CARRIAGE



## Carriage, Left End Outside

Diagram No.	Part No.	Description
1 .....	B374801 .....	Screw, Hex 3/8 -16x3
2 .....	09337 .....	Spring
3 .....	K370001 .....	Washer, Flat 3/8

# PARTS LIST: CARRIAGE

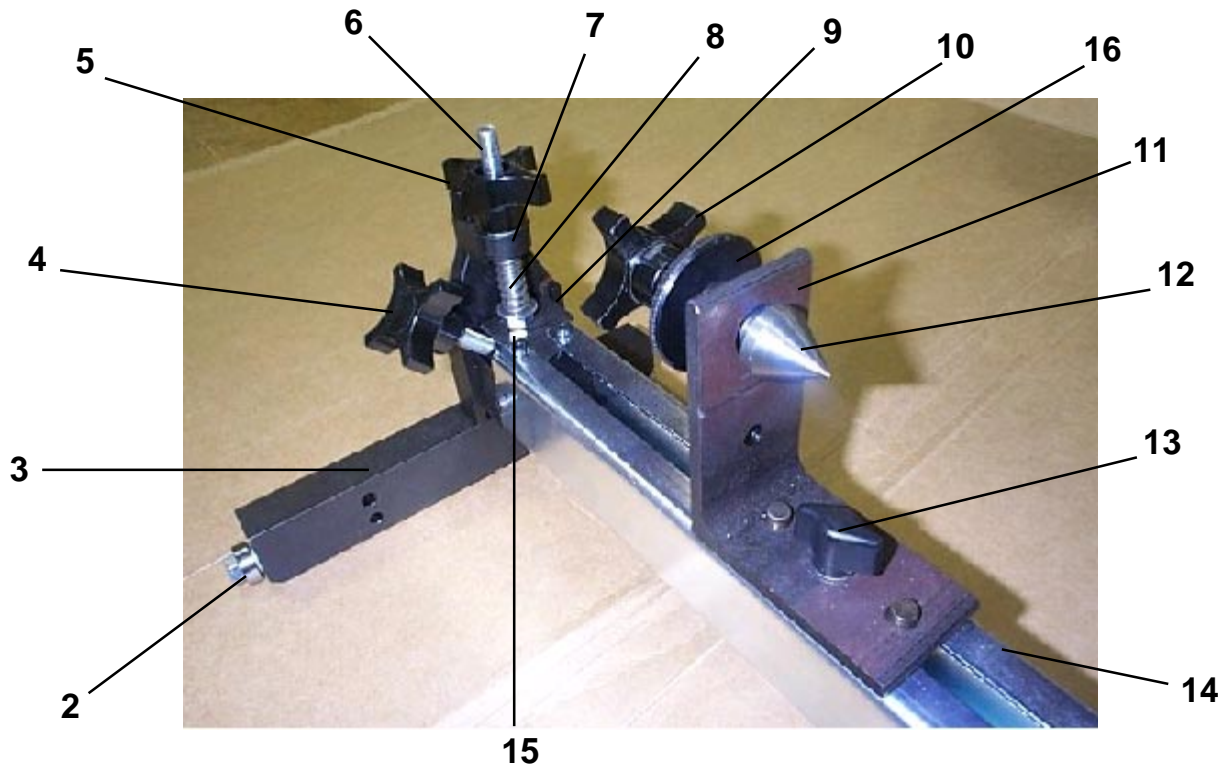

**Carriage, Left End Inside**

Diagram No.	Part No.	Description
2	09312	Bearing
2	B371201	Screw, Hex 3/8-16 x .75
2	K371501	3/8 Lockwasher
2	09054	Washer, Flat
3	20032	Base, Carriage
4	09314	Knob
5	09324	Knob
6	20008	Threaded Stud 3/8-16 x 4-1/2
7	20029	Slide
7	09111	Screw, 5/16-18 x 2
7	K311501	Washer, Lock 5/16
8	09337	Spring
8	K370001	Washer
8	J371000	Nut
9	20030	Block, with hole
9	20031	Block, with stud
10	09340	Knob
11	20043	Center Support, Weldment
12	20042	Center, Threaded
13	80169	Knob
13	80252	Rod, Threaded
13	K311501	Washer, Lock
13	20058	Nut, Tee
14	20033	Bar, Trunnion
15	B190611	Screw 10-24 x 3/8 Socket Head
16	3849265	Tapered Locking Collar

# PARTS LIST: CARRIAGE



## Carriage, Bedknife Support

Diagram No.	Part No.	Description
1 .....	•09268 .....	Screw, 3/8-16 x 3 Full Thread
1 .....	•J371000 .....	Hex Nut 3/8-16
1 .....	•K371501 .....	Lockwasher 3/8
2 .....	•20040 .....	Plate, Slotted
3 .....	•B314401 .....	Screw, 5/16-18 x 2-3/4 HHCS
3 .....	•K310101 .....	Washer
3 .....	•20058 .....	Nut, Tee 5/16 - 18
3 .....	•K311501 .....	Lockwasher 5/16

• Shipped in Carton Assembly

# PARTS LIST: CARRAIGE

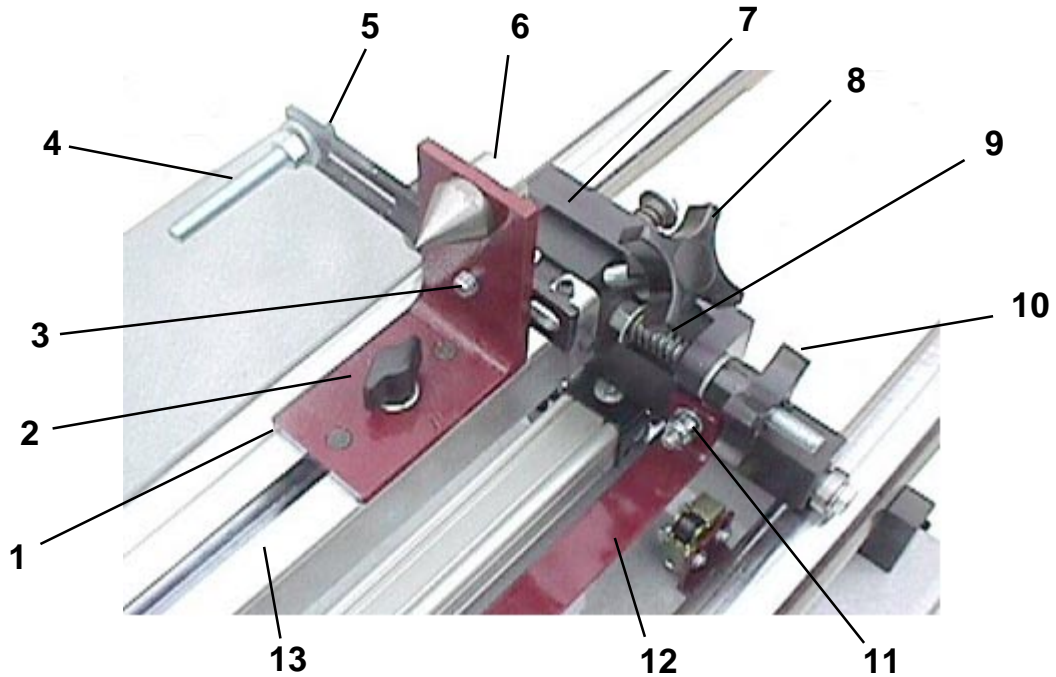

**Carriage, Right End Inside**

Diagram No.	Part No.	Description
1	20039	Center Support Angle LH
2	80169	Knob 5/16 - 18
2	80252	Rod, Threaded 5/16 - 18 x3
2	K311501	Washer, Lock
2	20058	Nut, Tee 5/16 - 18
3	B371201	Screw, 3/8-16 x .75
3	K371501	Lock Washer 3/8
4	^09268	Screw, 3/8-16 x 3
4	^K370001	Washer
4	^J371000	Nut
5	^20041	Arm - Adjusting
6	20047	Center (not threaded)
6	09335	Lock Collar
7	20030	Block, with hole
7	20031	Block, with stud
8	09314	Knob
9	09337	Spring
9	20008	Threaded Stud 3/8-16 x 4-1/2"
9	K370001	Washer 5/16
9	J371000	Nut-lock 5/16 - 18
10	09324	Knob
11	*B312801	Screw, 5/16 - 18
11	*K310001	Washer 5/16
11	*J317100	Nut-lock 5/16 - 18
12	*25007	Bar, Travel Drive
13	20033	Bar, Trunnion
13	B190611	Screw 10-24 x 3/8 Socket Head

^ Shipped in Carton Assembly

\* Part of Traverse Kit 20520

# PARTS LIST: CARRIAGE

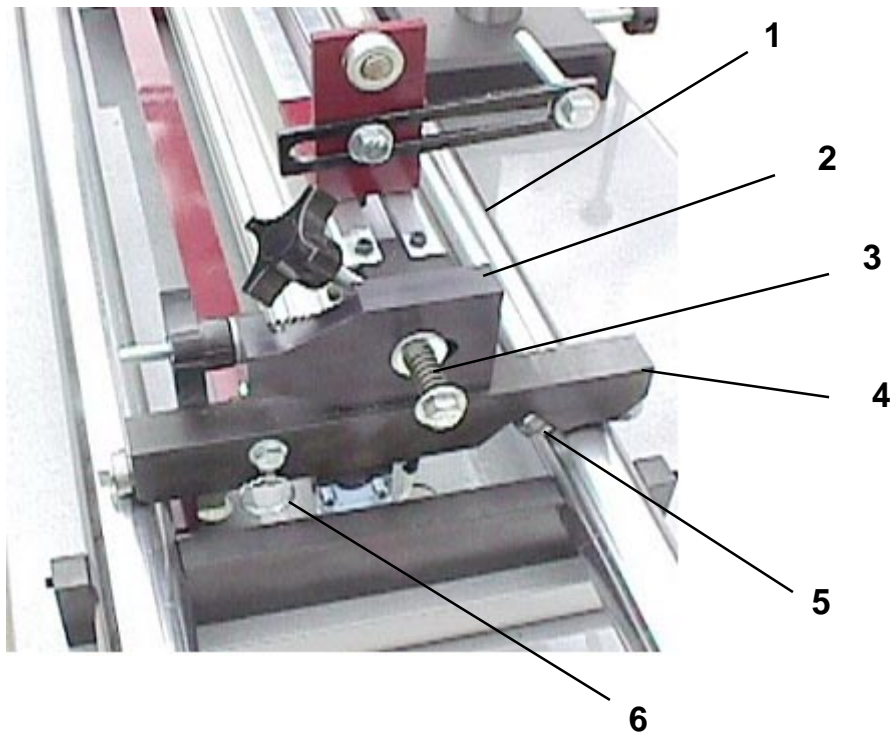

## Carriage, Right End Inside

Diagram No.	Part No.	Description
1 .....	20028 .....	Rail
2 .....	20029 .....	Slide
.....	09111 .....	Screw, Hex 5/16 - 18 x 2
.....	K311501 .....	Washer, Lock 5/16
3 .....	B374801 .....	Screw, Hex 3/8 - 16 x 3
.....	09337 .....	Spring
.....	K370001 .....	Washer, Flat
4 .....	20032 .....	Base, Carriage
5 .....	09312 .....	Bearing
.....	B371201 .....	Screw, Hex 3/8 - 16 x .75
.....	K371501 .....	3/8 Lockwasher
.....	09054 .....	Washer, Flat
6 .....	*09387 .....	Pin, Dentent Ring

\* Part of Traverse Kit 20520

# PARTS LIST: RAIL SUPPORT

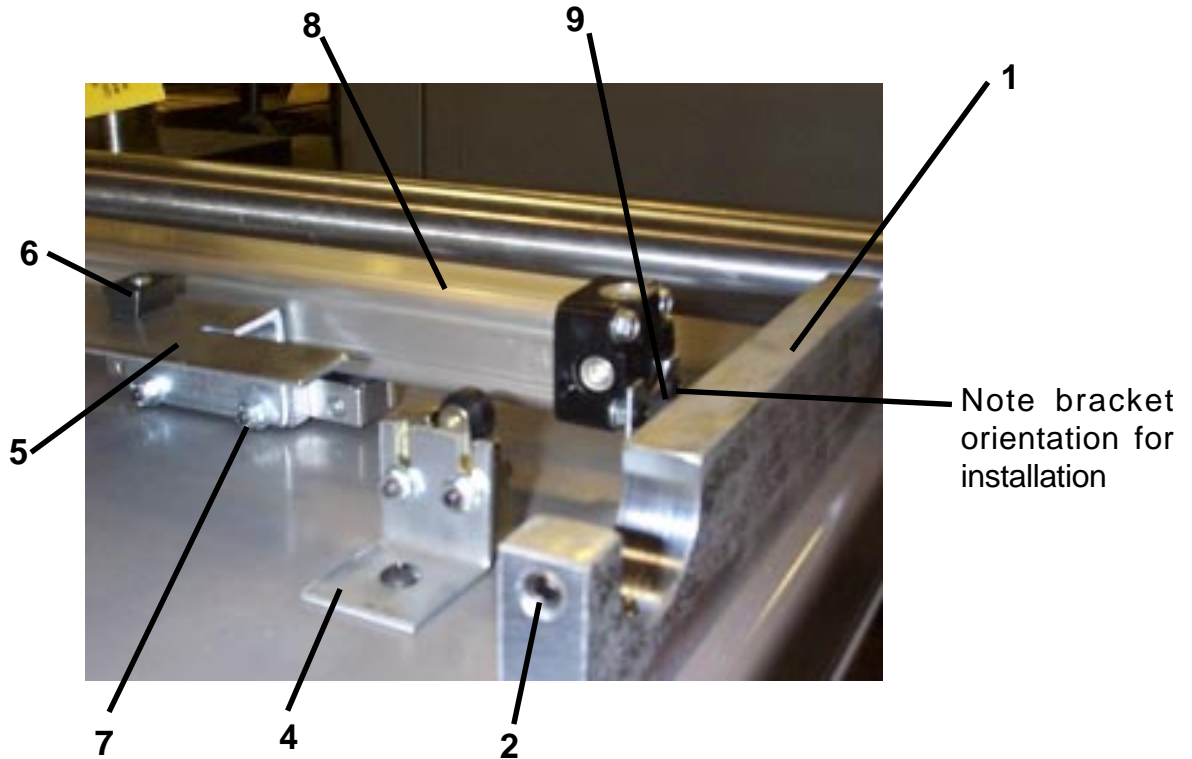

**Carriage, Right End Inside**

Diagram No.	Part No.	Description
1	20038	Saddle
1	B371601	Screw, Hex 3/8-16 x 1
1	K371501	Washer, Lock 3/8
2	C371220	Screw, set 3/8-16 x 3/4
4	*25009	Bracket, Limit Switch
4	*B251216	Screw, 1/4-20 x .75
4	*J257100	Nut, Lock 1/4-20
4	*09379	Switch, Limit
4	*09522	Screw, 8-32 x 1.0 shcs
4	*K161501	Lock Washer #8
4	*J161000	Nut, #8-32
4	*K160001	Washer, #8
5	*25003	Actuator
5	*25002	Spacer
5	*25001	Plate, Drive
6	*25004	Cog, Threaded
6	*K311501	Washer, Lock 5/16
6	*B311201	Screw, 5/16-18 x .75 HHCS
7	*B192811	Screw, 10-24 x 1.75 SHCS
7	*K190001	Washer, #10
7	*K191501	Washer, #10
7	*J191000	Nut, 10-24
8	*09373	Cylinder, only
8	*25008	Spacer
9	*B192011	Screw, 10-24 x 1 - 1/4
9	*J197000	Nut, Lock 10-24

\* Part of Traverse Kit 20520

# ADJUSTMENTS

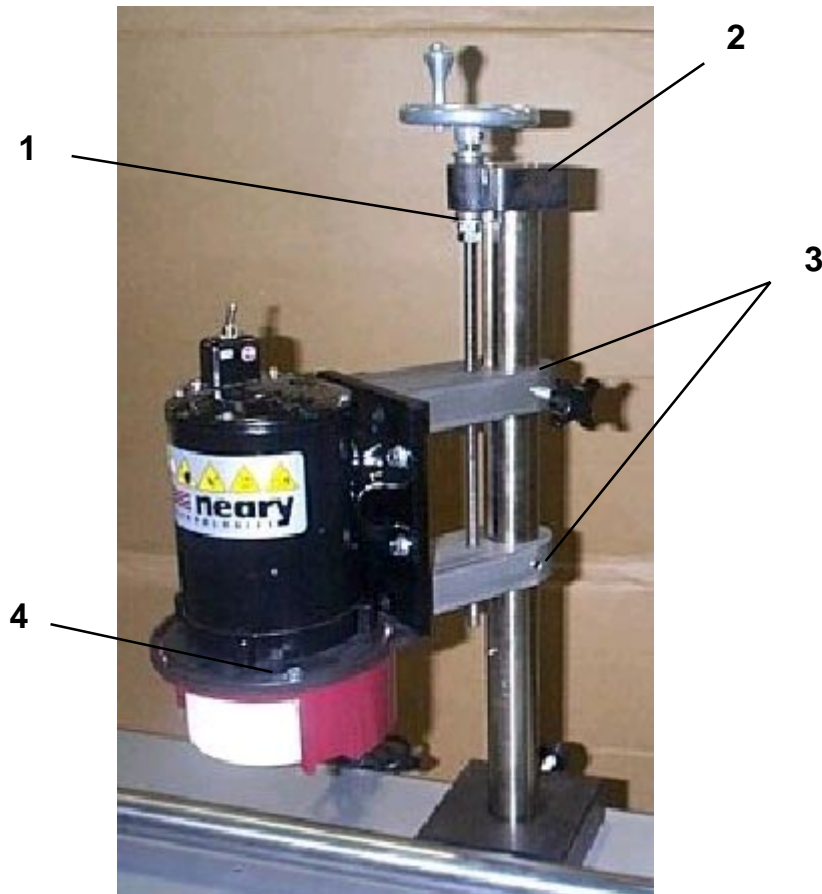

## Adjustments

1. The lead screw/threaded rod should have zero play when reversing the hand wheel. Check to assure that the hand wheel and top nut are locked together. Then adjust for play with the nut under the support. Then secure the adjustment by locking the two nuts together, under the support.
2. There are set screws in the back of the top cap to secure it to the column. These set screws should be tight.
3. There are set screws in the back of these parts. The set screws have nylon pads under them to prevent damage to the column. The set screws in the motor mount should be adjusted so that there is zero play, but allow the motor mount to slide freely up and down the column.
4. The screws that hold the tube of the guard to the top of the guard should be adjusted so that the spring washers hold the guard in place, yet allow the guard to be rotated as the grinding head is moved toward or away from the bedknife.



**The guard must be in place during the grinding process.**

# PARTS LIST: SWITCH

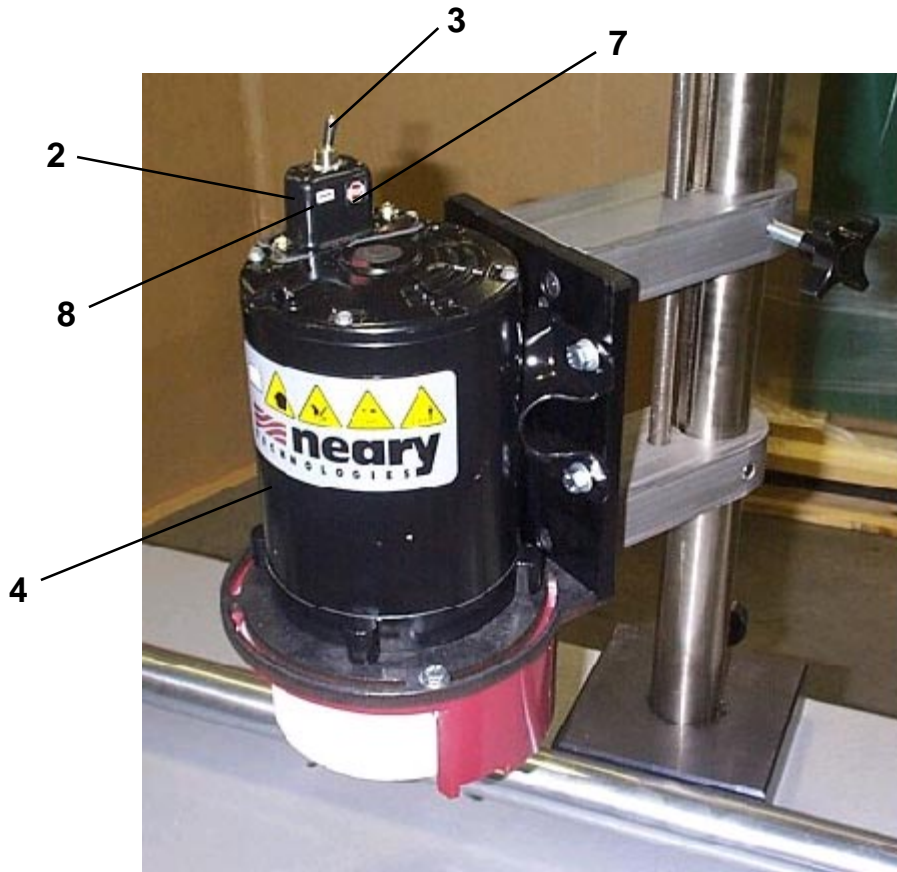

## Switch, Electrical Box

Diagram No.	Part No.	Description
1 .....	3707034 .....	Cord, Power (not shown)
2 .....	3309073 .....	Box
3 .....	3707974 .....	Switch
4 .....	80320 .....	Motor
5 .....	3659580 .....	Wire Assembly (not shown)
6 .....	3707448 .....	Decal - Warning Electrical (not shown)
7 .....	3708459 .....	Decal - Stop
8 .....	3708460 .....	Decal - Start

# PARTS LIST: GUARD COVER

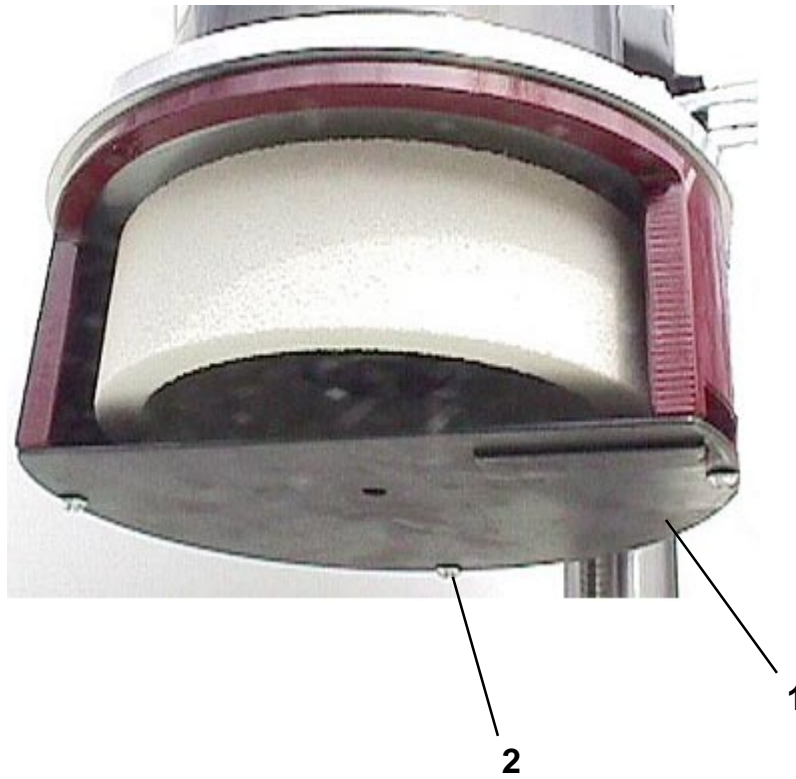

## Guard Cover

Diagram No.	Part No.	Description
1 .....	20054 .....	Cover, Guard
2 .....	B190802 .....	Screw

# PARTS LIST: GRINDING WHEEL, ADAPTER, FLANGES

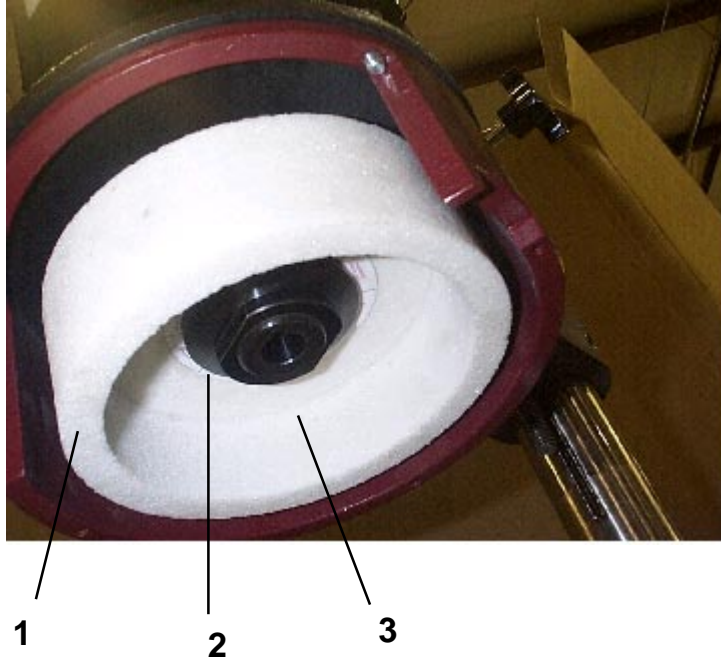

## Grinding Wheel, Adapter, Flanges

Diagram No.	Part No.	Description
1 .....	3700411 .....	Wheel, Straight Cup
1 .....	02710 .....	Wheel, Tapered Cup (optional)
2 .....	27110 .....	Flange - Outer
3 .....	27111 .....	Adapter, Grinding Wheel
3 .....	C250460 .....	Screw, Set, Adapter/Motor

# PARTS LIST: GUARD, GUARD MOUNT

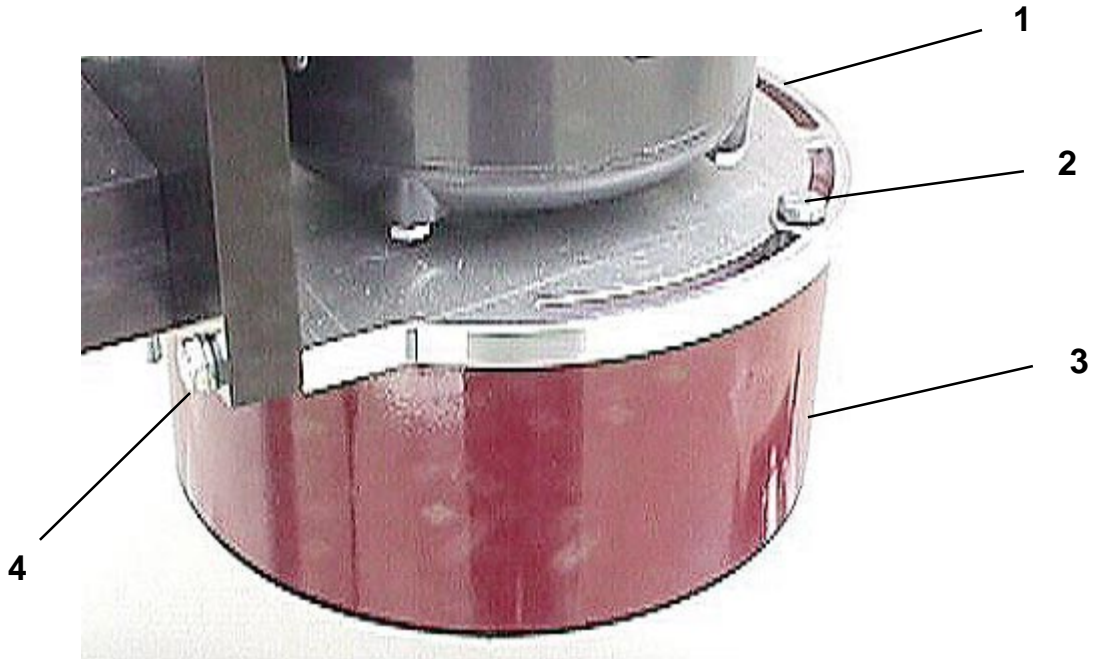

## Guard, Guard Mount

Diagram No.	Part No.	Description
1 .....	20052 .....	Top, Guard
2 .....	B251401 .....	Screw 1/4-20 x 7/8 HHCS
2 .....	K250001 .....	Washer Flat 1/4
2 .....	09072 .....	Washer, Wave
3 .....	20053 .....	Tube, Guard
4 .....	B252001 .....	Screw 1/4-20 x 1-1/4 HHCS
4 .....	K251501 .....	Washer, Lock 1/4

## PARTS LIST: HAND WHEEL

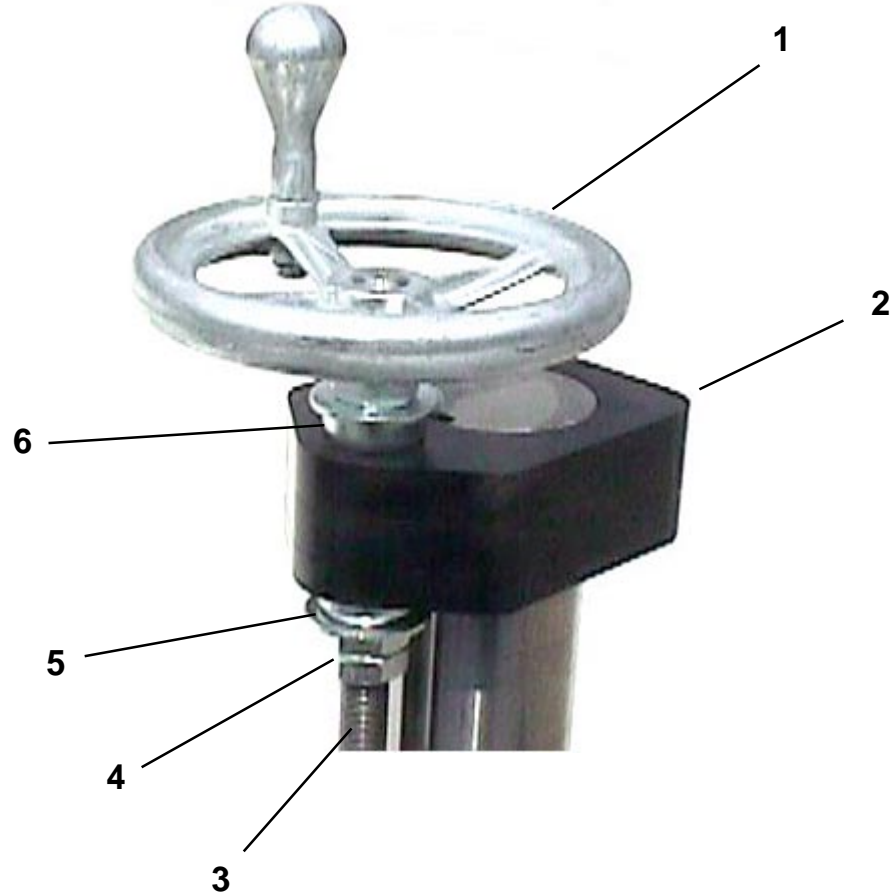

### Hand Wheel, Vertical Adjustment

Diagram No.	Part No.	Description
1 .....	09346 .....	Hand Wheel
2 .....	20003 .....	Cap
2 .....	C310820 .....	Screw, Set 5/16 - 18 x 1/2
3 .....	20026 .....	Rod, 1/2-13 x 18" HT
4 .....	J502000 .....	Nut, 1/2-13
5 .....	09055 .....	Washer, Flat 7/16
6 .....	3709042 .....	Bearing

# PARTS LIST: MOTOR

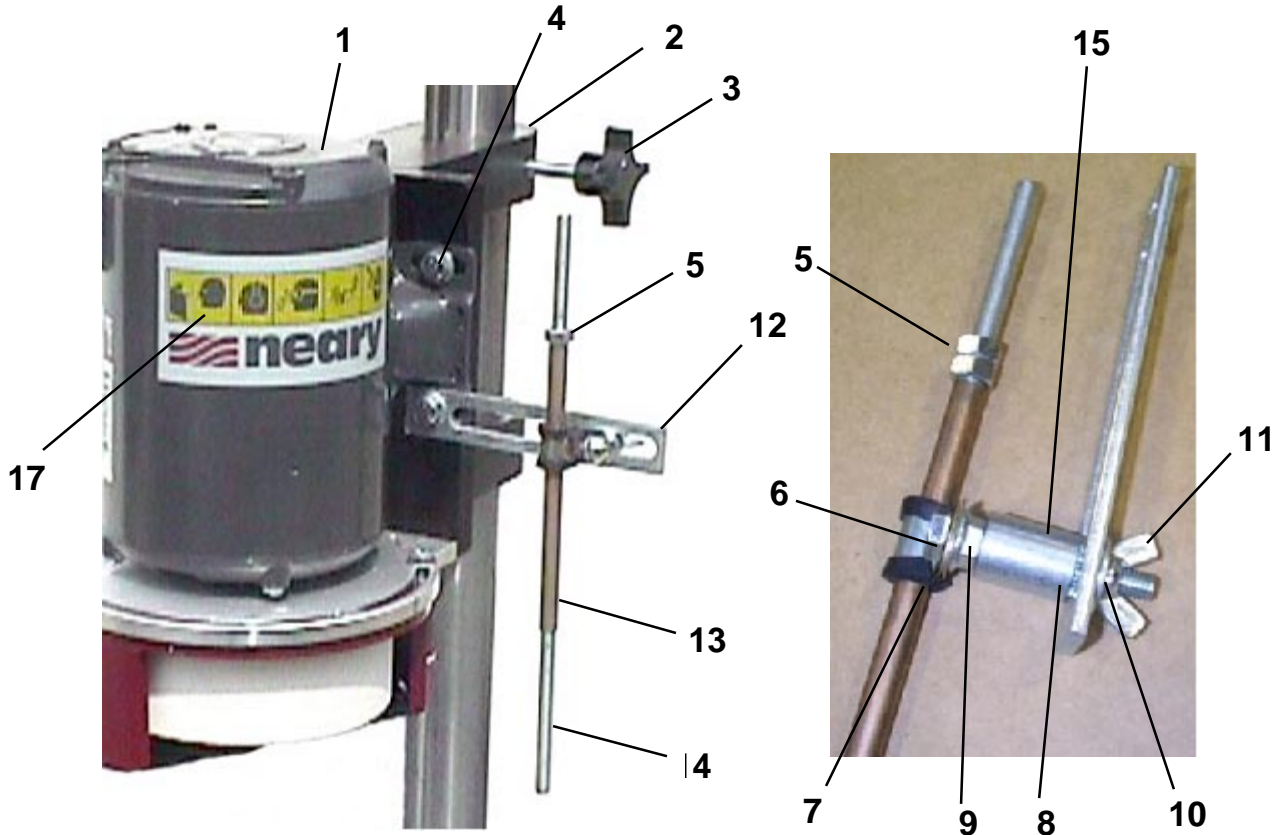

## Motor, Motor Mount, Gauge

Diagram No.	Part No.	Description
1 .....	20504 .....	Motor Assembly
2 .....	20051 .....	Mount Motor Assembly
2 .....	C310820 .....	Screw, Set 5/16-8 x 1/2
2 .....	3579109 .....	Plug Nylon 3/16 Diameter
3 .....	09314 .....	Knob
4 .....	B311401 .....	Screw, 5/16-18 x 7/8 HHCS
4 .....	K311501 .....	Washer, Lock 5/16
4 .....	K310001 .....	Washer, Flat 5/16
5 .....	J311100 .....	Nut, 5/16-24
6 .....	A313201 .....	Screw 5/16-18 x 2-1/4 HHCS Full Thread
7 .....	09308 .....	Clip
8 .....	K310201 .....	Washer, Star Lock 5/16
9 .....	09004 .....	Nut, Flange 5/16
10 .....	09052 .....	Washer, Flat 5/16
11 .....	09005 .....	Nut, Wing 5/16
12 .....	3969027 .....	Adjusting Arm
13 .....	09307 .....	Tube
14 .....	09306 .....	Rod, Threaded 5/15-24 x 12"
15 .....	3969065 .....	Spacer
16 .....	09339 .....	Gauge, Includes 5-15 (not shown)
17 .....	80151 .....	Decal-Logo & Warning

# PARTS LIST: COLUMN & SUPPORT

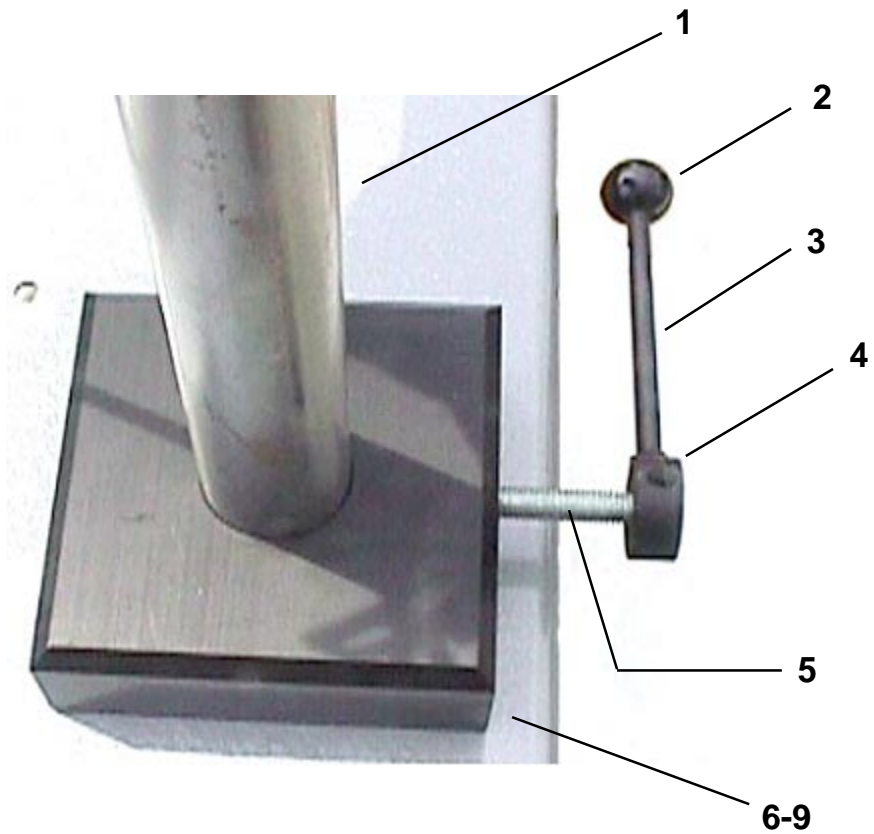

## Column & Support

Diagram No.	Part No.	Description
1 .....	20006 .....	Column
2 .....	09351 .....	Knob
3 .....	20012 .....	Lock Handle Weldment
4 .....	C310820 .....	Screw, Set 5/16-18 x /5
5 .....	40009 .....	Rod Threaded
6 .....	20011 .....	Base - Column
8 .....	B371201 .....	Screw, 3/8-16 x .75
9 .....	K371501 .....	Washer, Lock 3/8

# PARTS LIST: TABLE

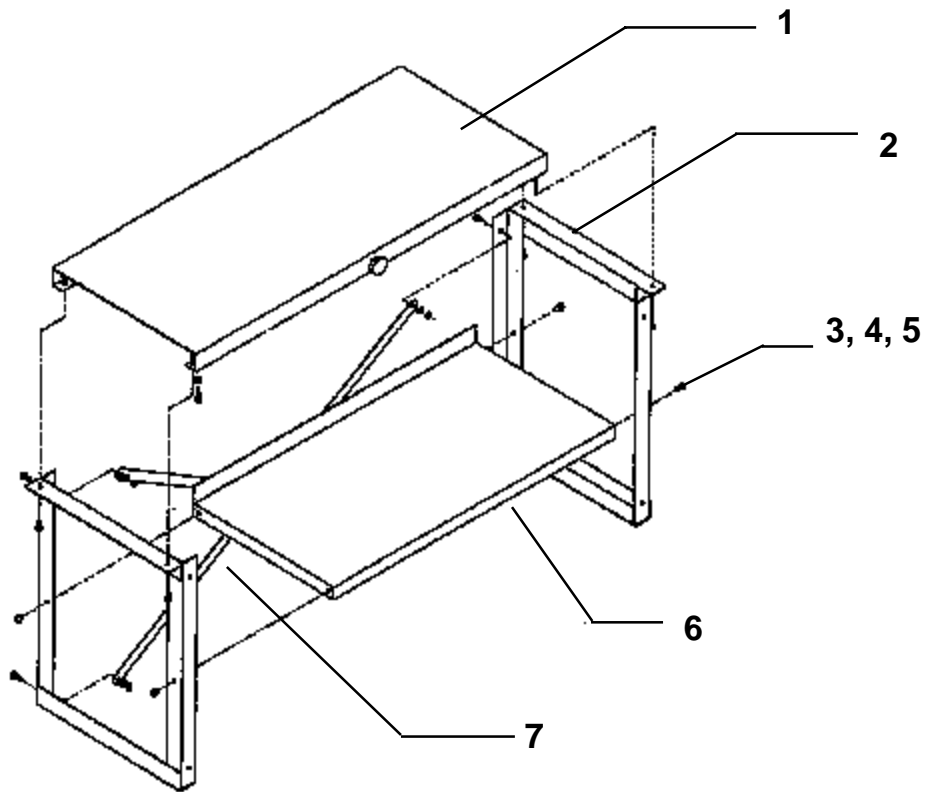

## Table

Diagram No.	Part No.	Description
1 .....	25010 .....	Table Weldment
2 .....	20034 .....	Leg Weldment
3 .....	B371201 .....	Screw, 3/8-16 x .75 HHCS
4 .....	K371501 .....	Washer, Lock 3/8
5 .....	J371000 .....	Nut, 3/8-16
6 .....	20021 .....	Tool Tray
7 .....	20024 .....	Stiffener-Base

## TRAVERSE KIT (20520) Optional

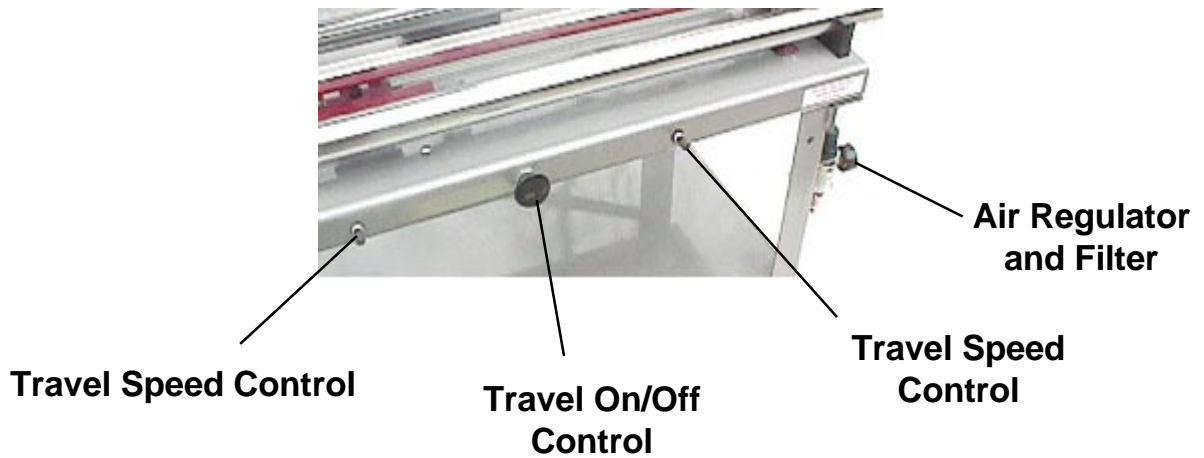

**Travel On/Off Control:** The travel control knob turns the travel on and off controlling the side to side movement of the carriage. This is the knob in the center of the front of the table.

**Travel Speed Control:** These control knobs determine the speed of travel for the grinding carriage. When turned to minimum, the carriage should stop. When turned to the maximum, the carriage moves back and forth at full speed. There is one control on each side of the front of the table. One controls the travel speed to the left, the other controls the travel speed to the right.

**Travel Mechanism Release:** There is a cog on the travel cylinder and a cogged bar on the carriage. The cogged bar is held in place by a ring pin on one end of the carriage. To release the travel bar from the cylinder, remove the ring pin and rotate the bar.

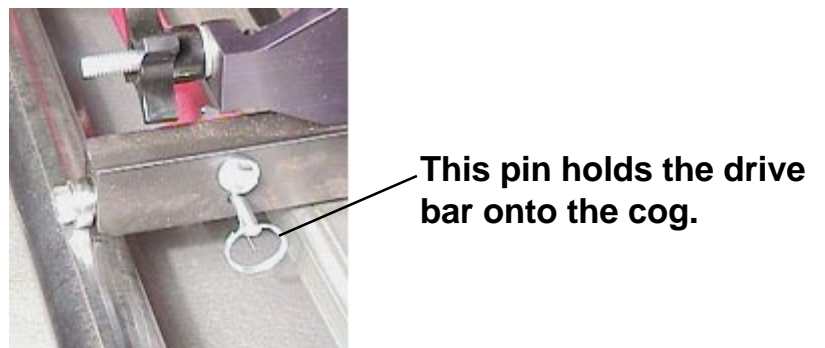
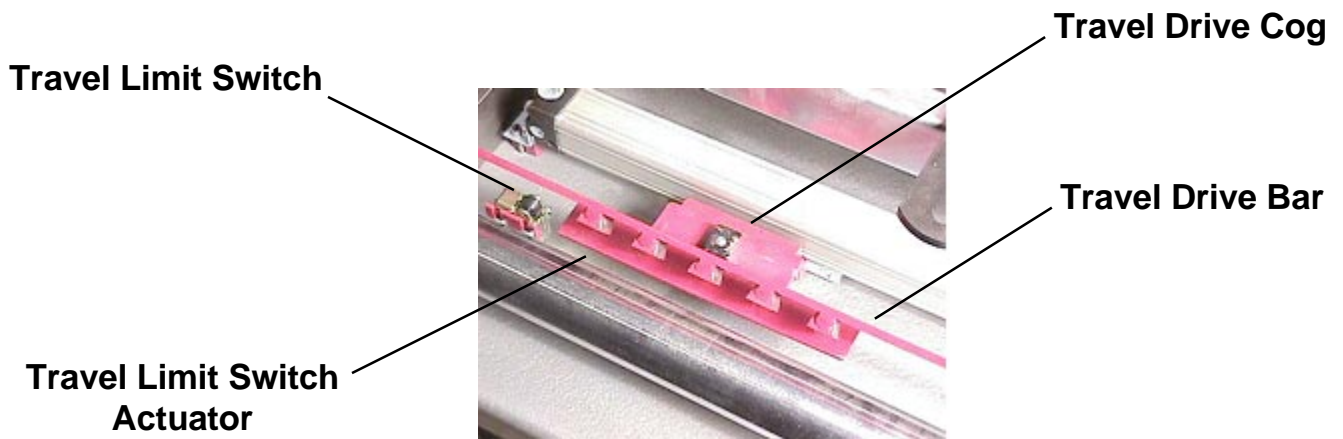

## TROUBLE SHOOTING TRAVERSE KIT (20520)

<b>Symptom</b>	<b>Cause</b>	<b>Remedy</b>
Grind Motor will not start.	Motor not plugged into outlet. Circuit breaker at service panel is tripped.	Plug into outlet. Reset the breaker.
Auto Travel does not move	Speed turned too low. Carriage not engaged to bar. Air supply not connected to regulator. Compressor not turned on. Regulator set too low.	Increase travel speed. Engage to bar. Connect air supply. Turn on compressor. Increase pressure in system.
Carriage does not change direction.	Travel speed set too low on one end. Actuator on cylinder not hitting switch.	Adjust travel speed. Adjust actuator and switch.
Carriage movement not smooth.	Travel speed set too low.	Turn up travel speed.

## Pneumatic Traverse Kit (20520) Cylinder and Valves

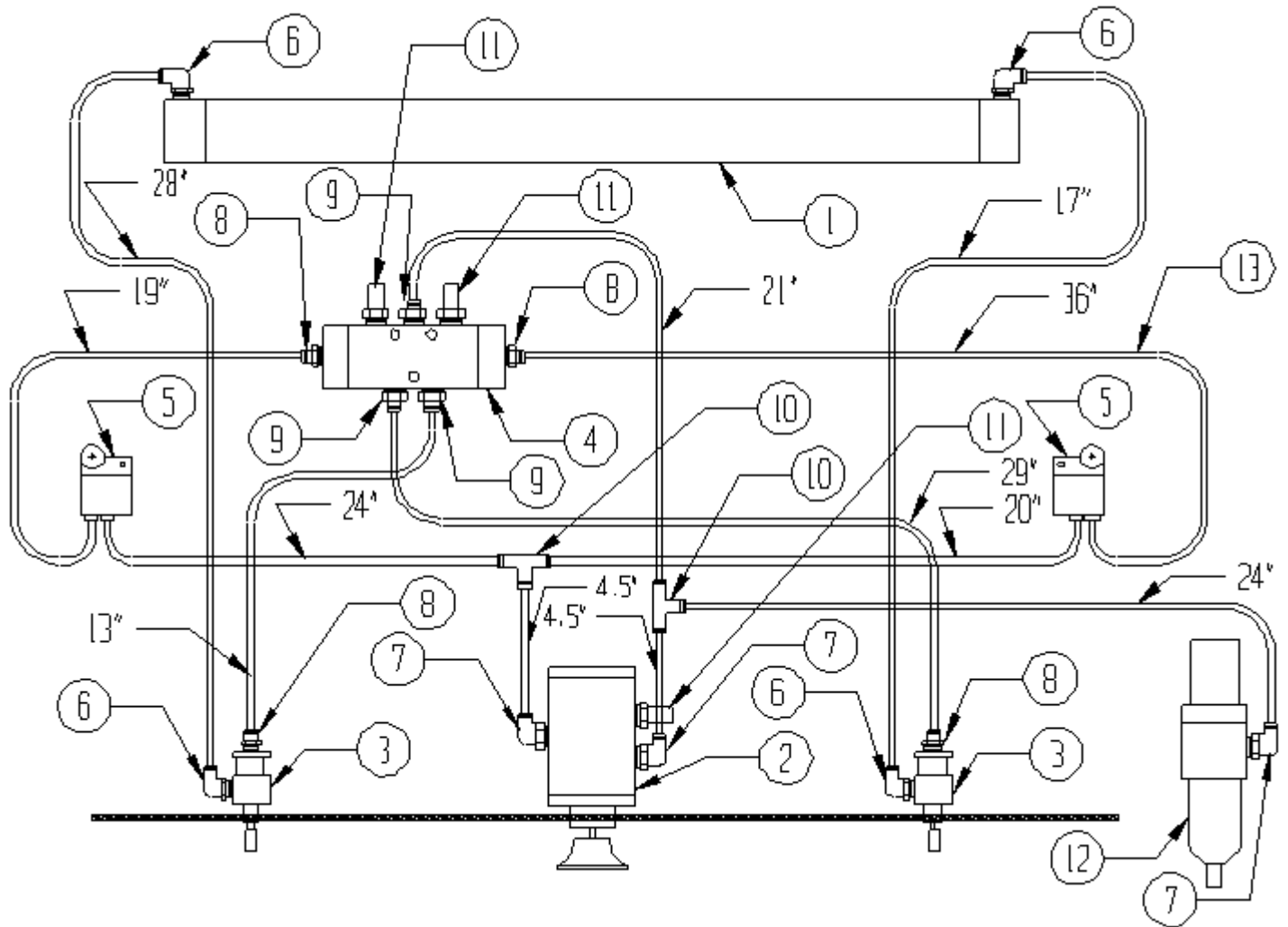

1 .....	09373 .....	Cylinder (1)
2 .....	09376 .....	Valve - Start/Stop (1)
3 .....	09378 .....	Flow Control (2)
4 .....	09377 .....	Valve - 4 way (1)
5 .....	09379 .....	Switch - Limit (2)
6 .....	09381 .....	Elbow - 5/32 tube x 1/8 NPT (4)
7 .....	09382 .....	Elbow - 5/32 tube x 1/4 NPT (3)
8 .....	09383 .....	Coupling - 5/32 tube x 1/8 NPT (4)
9 .....	09384 .....	Coupling - 5/32 tube x 1/4 NPT (3)
10 .....	09385 .....	Tee - 5/32 tube (2)
11 .....	09386 .....	Muffler - 1/4 NPT (3)
12 .....	09876 .....	Filter / Regulator (1)
13 .....	09380 .....	Tube - 5/32 (20 ft.)
14 .....	09877 .....	Gauge - Regulator (1) NOT SHOWN
15 .....	09375 .....	Bracket-Cylinder Mount(2) with 2 screws NOT SHOWN
16 .....	09982 .....	Bracket - Regulator Mount (1) NOT SHOWN
17 .....	80295 .....	Ring - Regulator Mount (1) NOT SHOWN
18 .....	09878 .....	Nipple 1/4 NPT (Optional) NOT SHOWN
19 .....	80185 .....	Lubricator (Optional) NOT SHOWN
20 .....	09912 .....	Seal repair kit for cylinder (Optional) NOT SHOWN

# TRAVERSE KIT (20520)

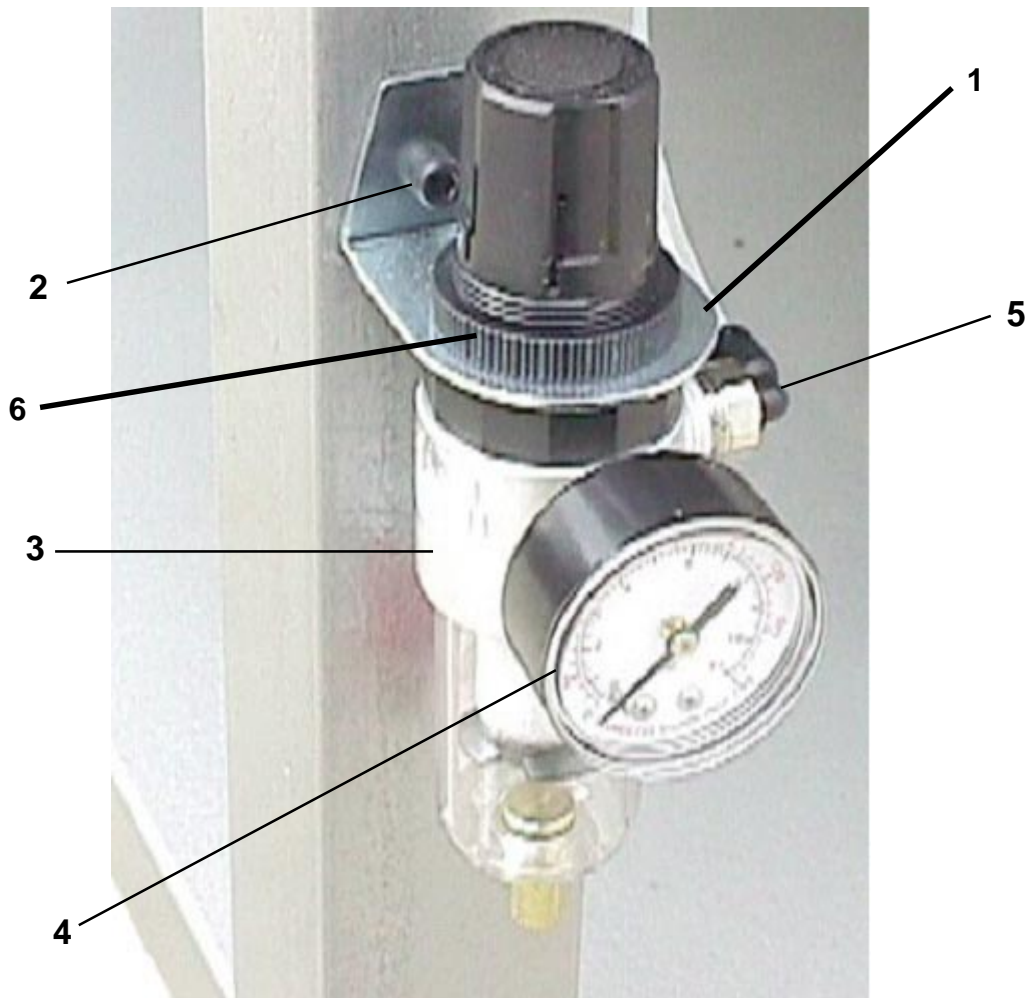

## Air Regulator & Filter

Diagram No.	Part No.	Description
1 .....	09982 .....	Bracket - Regulator Mount
2 .....	B190811 .....	Screw, 10-24 x .5 SHCS
2 .....	J197100 .....	Nut, 10-24
3 .....	09876 .....	Filter/Regulator
4 .....	09877 .....	Gauge Only
5 .....	09382 .....	Elbow
6 .....	80295 .....	Ring - Regulator Mount

# TRAVERSE KIT (20520)

## Photos to assist with installing the pneumatics on the Traverse Kit 20520

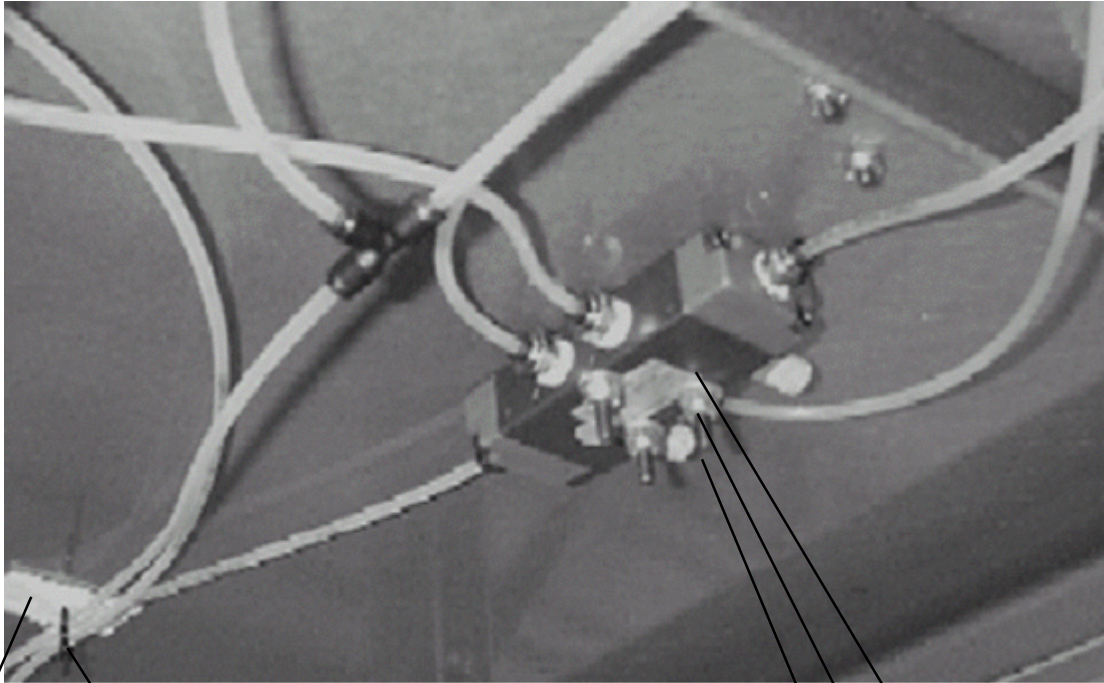

3707224  
Cable Tie Mount

3707225  
Cable Tie

K190001  
#10 Flat Washer

J197100  
10-24 Lock Nut

B192811  
10-24 x 1-3/4 SHCS

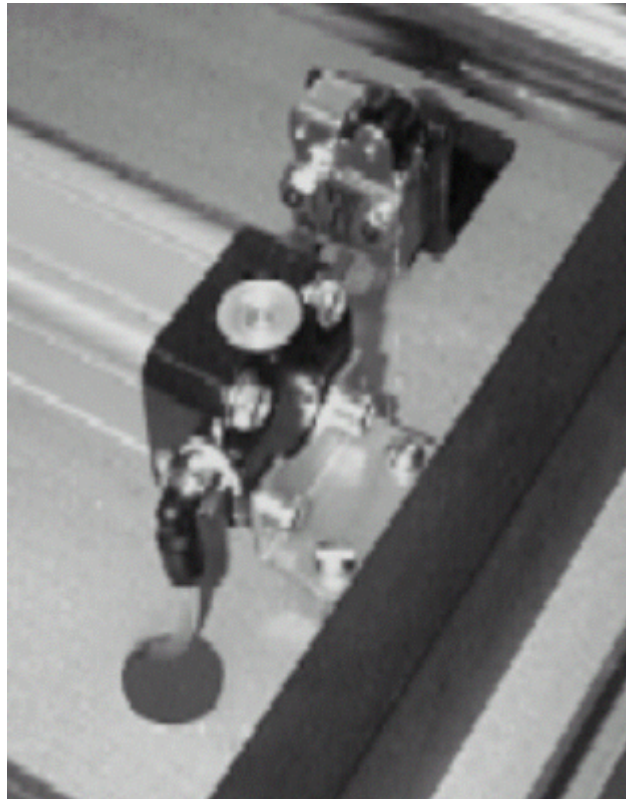

## TRAVERSE KIT (20520)

### Photos to assist with installing the pneumatics on the Traverse Kit 20520

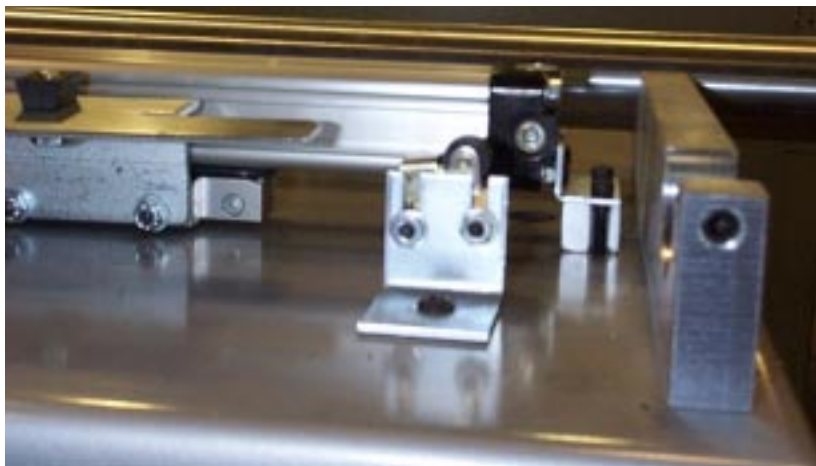
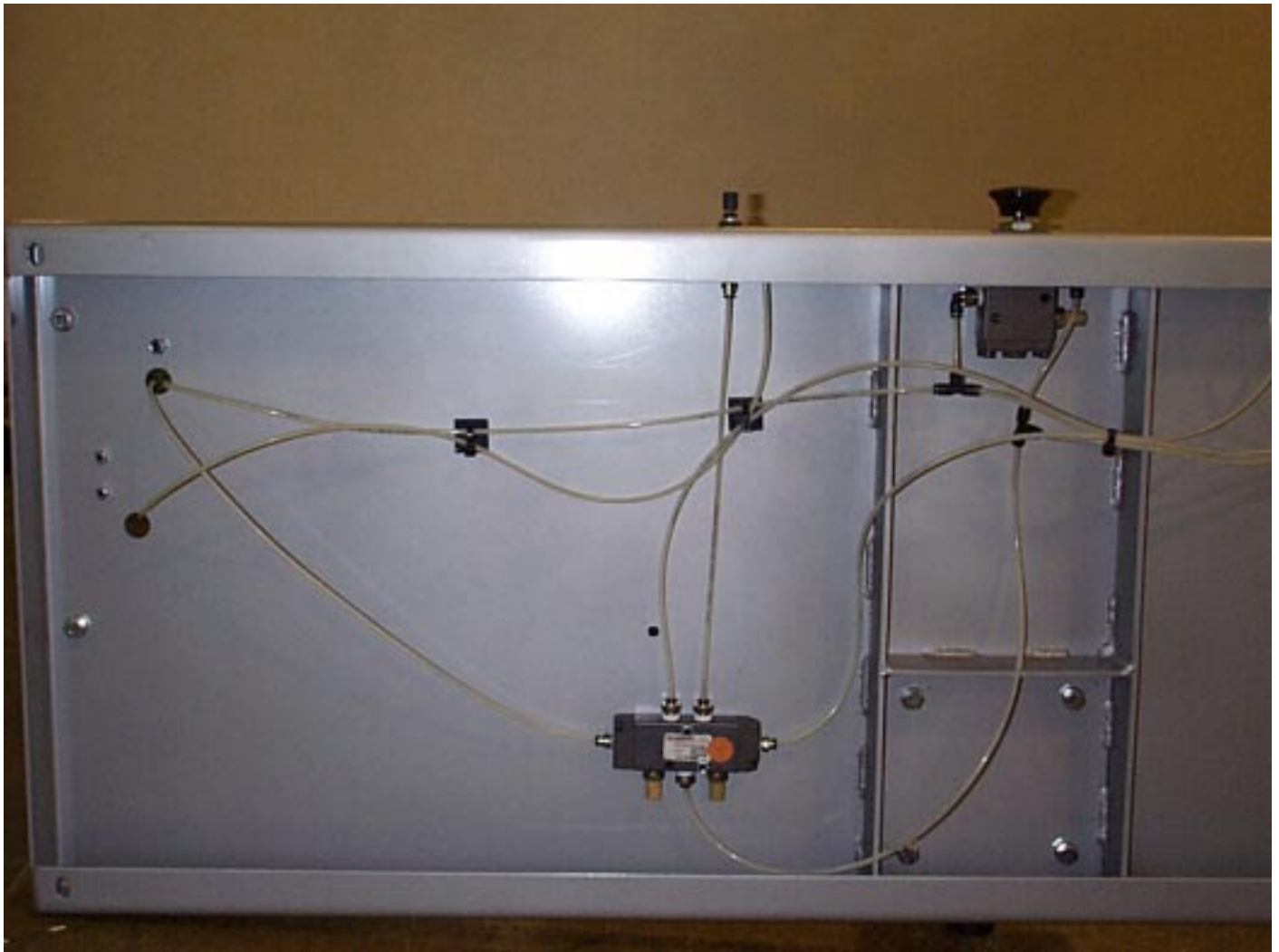

**Photos to assist with installing the pneumatics  
on the Traverse Kit 20520**

